

NAPA COUNTY

DEPARTMENT OF PUBLIC WORKS

SHERIFF OFFICE HVAC REPAIR

1535 AIRPORT BLVD
PW 22-08



GENERAL CONSTRUCTION NOTES:

1. Contractor agrees to assume sole and complete responsibility for the job site during the course of construction of this project, including safety of all persons and property; that this requirement shall apply continuously and not be limited to normal working hours; and that the contractor shall defend, indemnify, and hold the County and its representatives harmless from any and all liability, real and/or alleged, in conjunction with the performance of this project.
2. Contractor shall be held responsible for any and all damages to existing structures and utilities during construction.
3. Contractor shall verify locations, levels, distances, and features that may affect the work. Should existing conditions differ from those shown or indicated, or if it appears that these plans, standard specifications, and special provisions do not adequately detail the work to be done, contractor shall notify the engineer prior to continuing with any related work. No allowance will be made in Contractors behalf for any extra expense resulting from failure or neglect in determining the conditions under which work is to be performed. Noted dimensions take precedence over scale.
4. A set of signed working drawings and a set of specifications will be kept at all times at the job site on which all changes or variations in the work, including all existing utilities, are to be recorded and/or corrected daily and submitted to the County Engineer when the work to be done is completed.
5. Contractor shall provide and maintain sufficient temporary barriers to provide for the safety of the staff and public to the satisfaction of the Public Works Director and County Staff.
6. Contractor shall contact the County's Director of Public Works, or his/her designee, to arrange a pre-conference for the purpose of reviewing job requirements and County procedures.
7. All materials shall be furnished and installed by the contractor unless otherwise noted.
8. Contractor shall cooperate with all necessary staff relocations, if required, to facilitate making areas ready for work.
9. Contractor shall notify the Director of Public Works at least 72 hours in advance of commencement of any part
10. Contractor shall coordinate construction schedule with Engineer to minimize impact to tenants.
11. Contractor is responsible for procuring and paying for any Encroachment and or Transportation Permits.
12. Contractor shall work on the weekend only if required by any permits.
13. A LIVESCAN is required for all onsite workers.

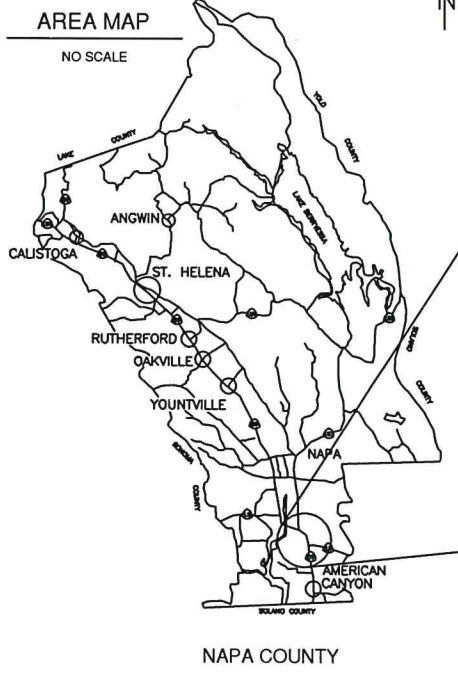
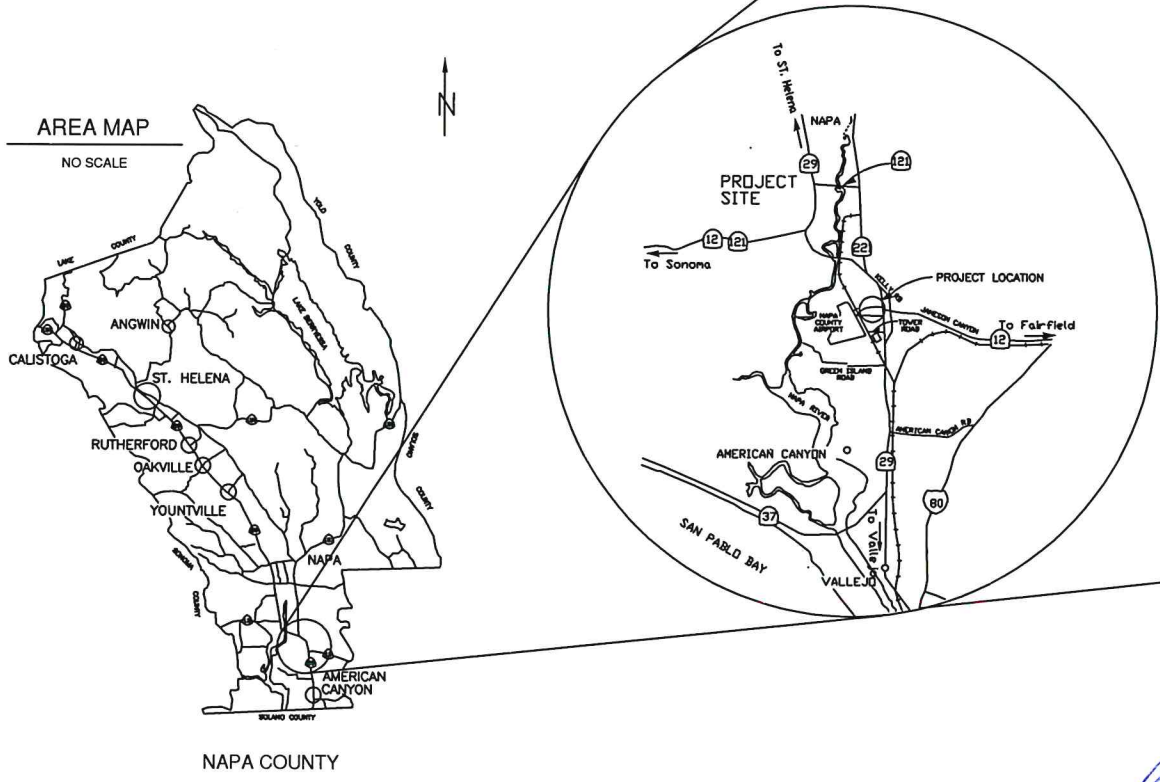
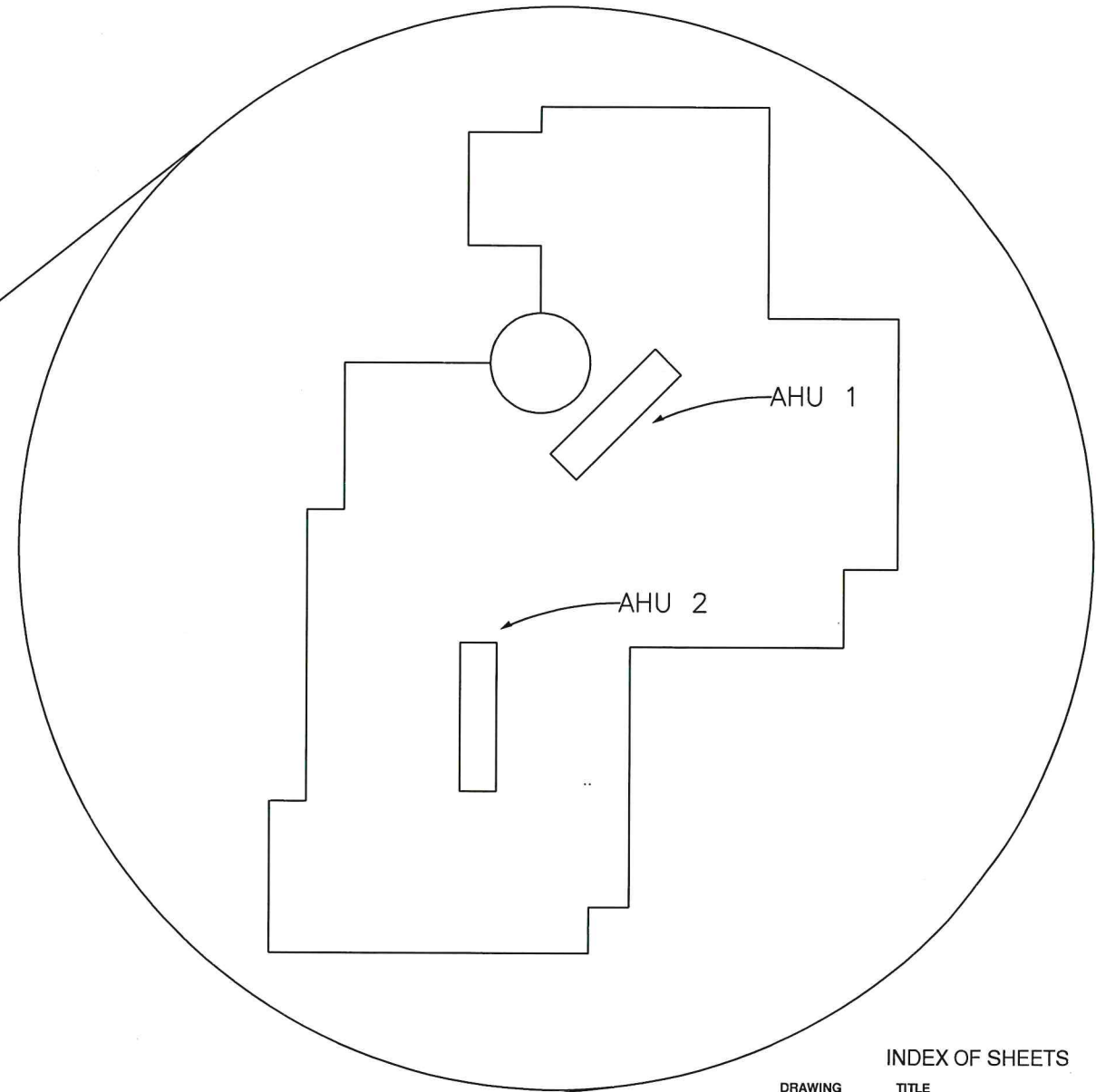

INDEX OF SHEETS

| DRAWING | TITLE |
|---------|----------------------------|
| T-1 | TITLE SHEET |
| M-2 | DEMO AND NEW WORK OVERVIEW |
| M-3 | MECHANICAL DETAILS |



| | |
|----------------------------|------------|
| COUNTY ENGINEER: JSE 63365 | |
| 5/09/22 | DESIGN: FL |
| SCALE: NTS | DRAW: FL |
| FILE NAME: Title Sheet.dwg | CHKD: |
| SURVEY NOTE: | |

| | |
|----------------|--------------|
| DRAWING | TITLE |
| T-1 | TITLE SHEET |
| PROJECT TITLE | |
| NAPA COUNTY | |
| SHERIFF OFFICE | |
| HVAC REPAIR | |
| PW 22-08 | SHEET 1 of 3 |

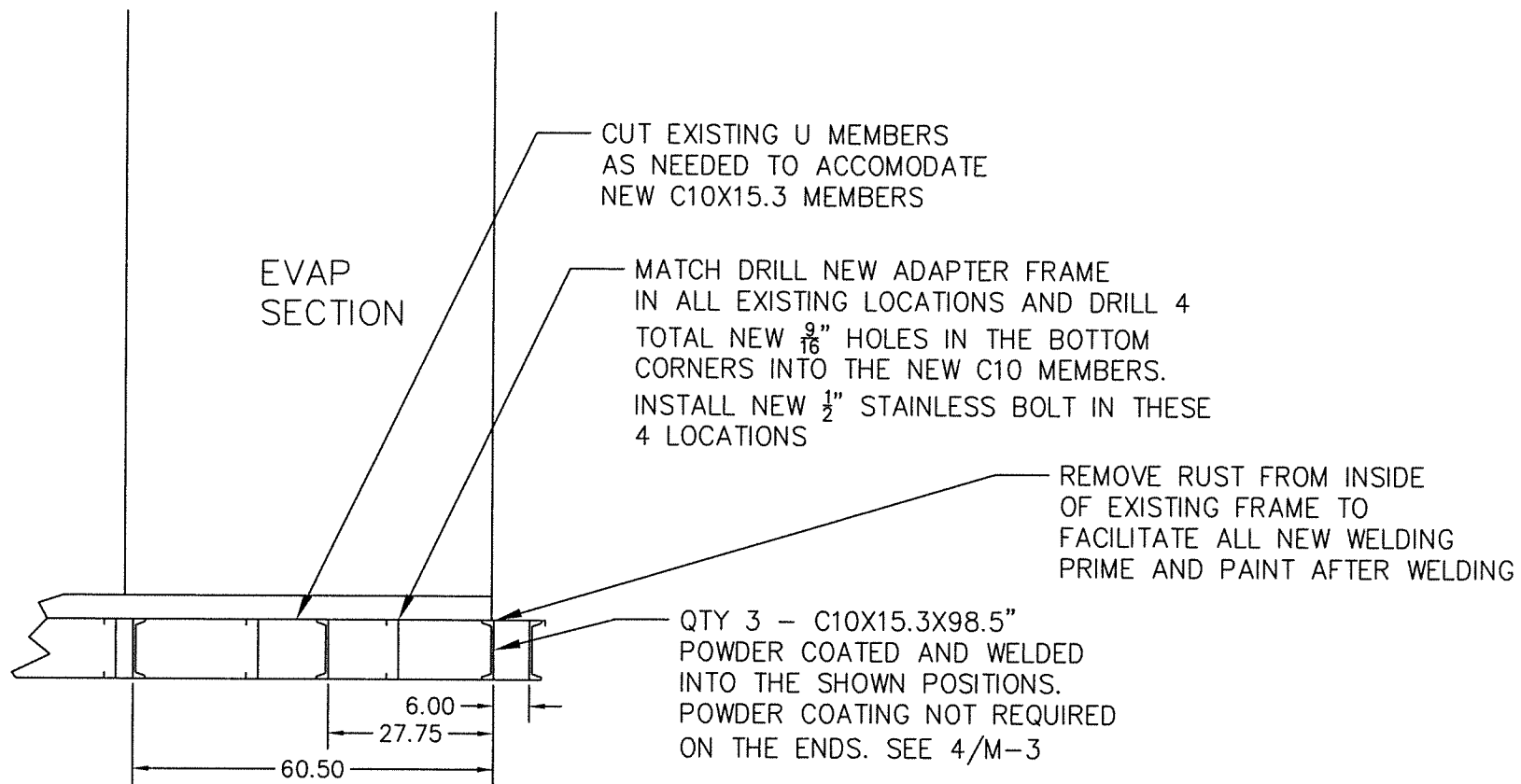

1
M-3 EXISTING FRAME REINFORCING

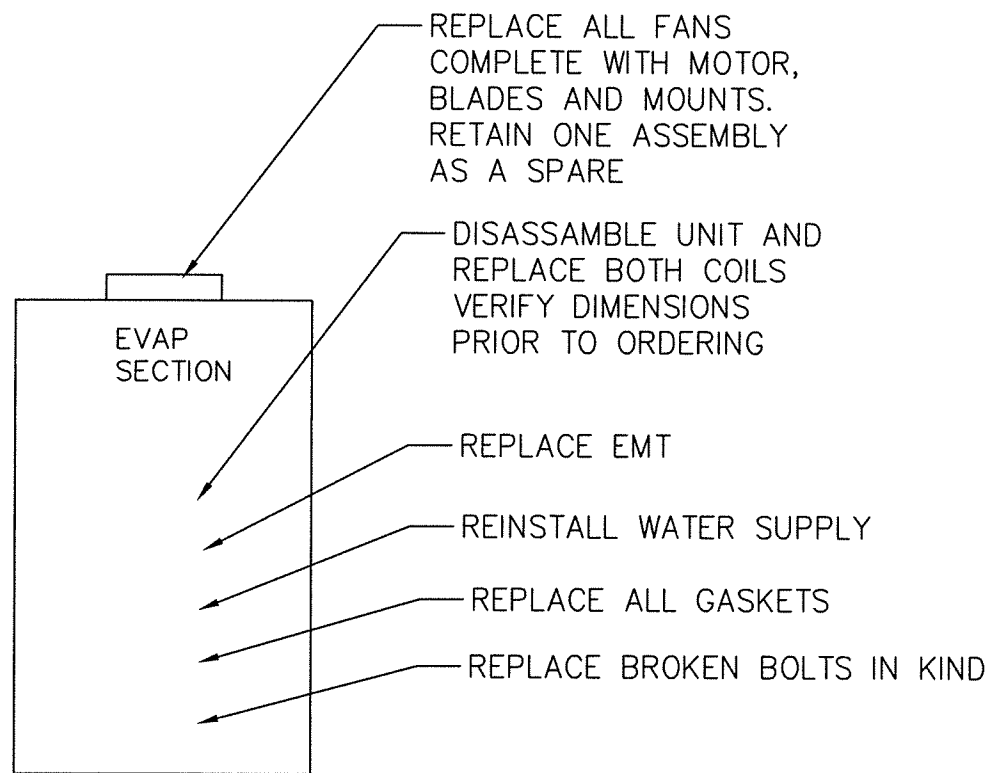

3
M-3 CONDENSER REPAIRS

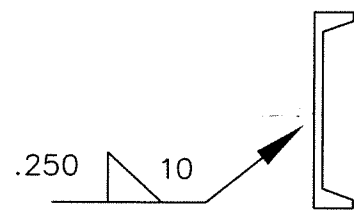

4
M-3 C10X15.3 WELDS

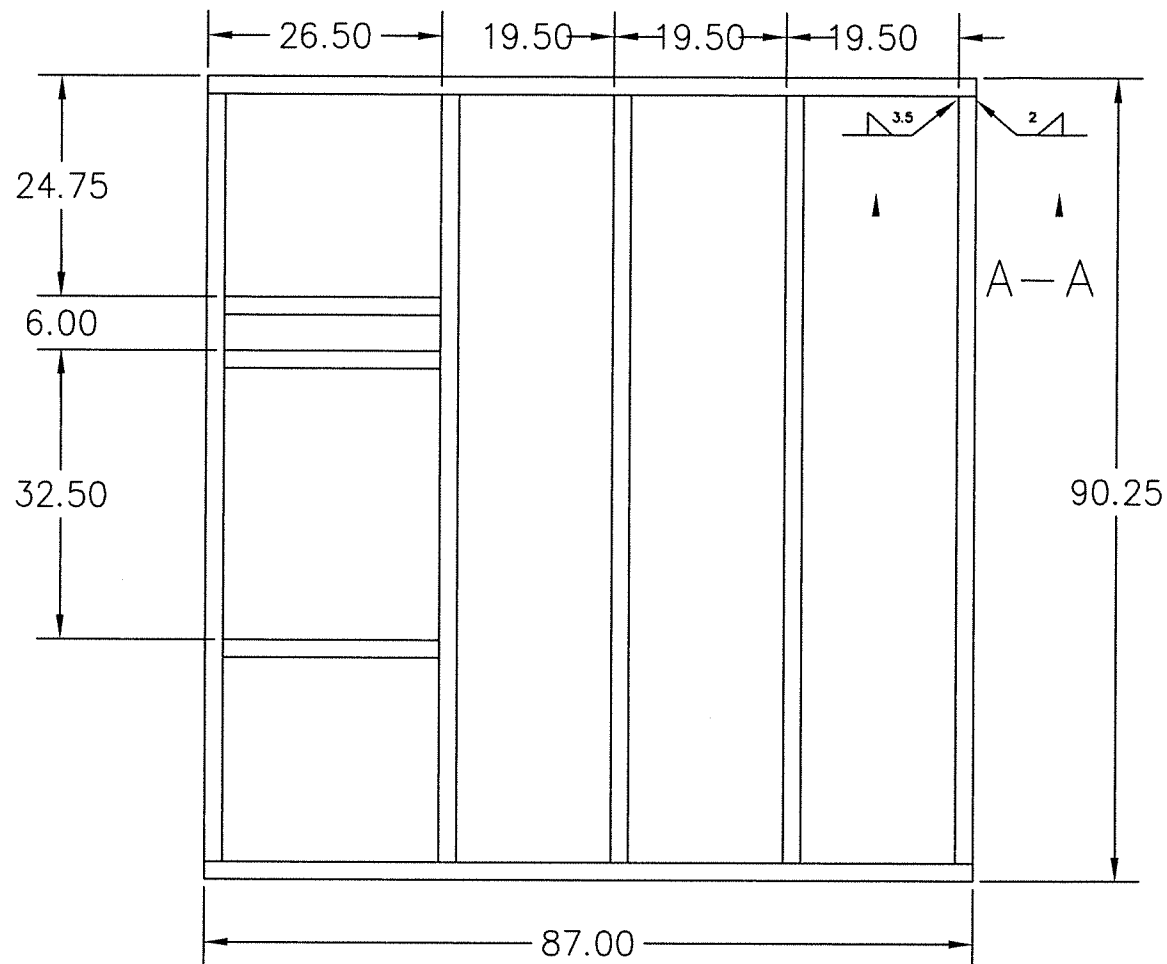

2
M-3 NEW ADAPTER FRAME

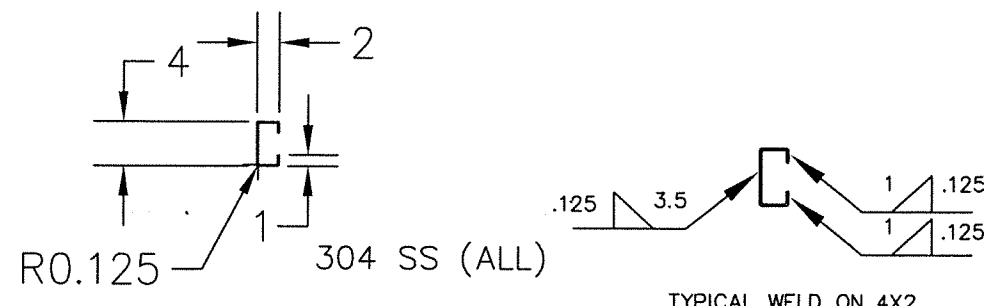

SECTION A-A

5
M-3 NEW ADAPTER FRAME MATERIAL AND WELDS

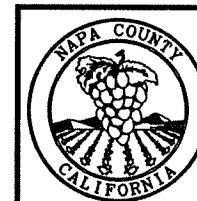

| | | |
|-------------------------------|------------|---|
| DATE: 5/22/22 | DESIGN: FL | DRAWING TITLE: M-3 DEMO AND NEW WORK |
| SCALE: NTS | DRWN: FL | PROJECT TITLE: NAPA COUNTY SHERIFF OFFICE HVAC REAIRS |
| FILE NAME: M-3-Mechanical.dwg | CHKD: | PW 22-08 |
| SURVEY NOTE: | | SHEET 3 of 3 |

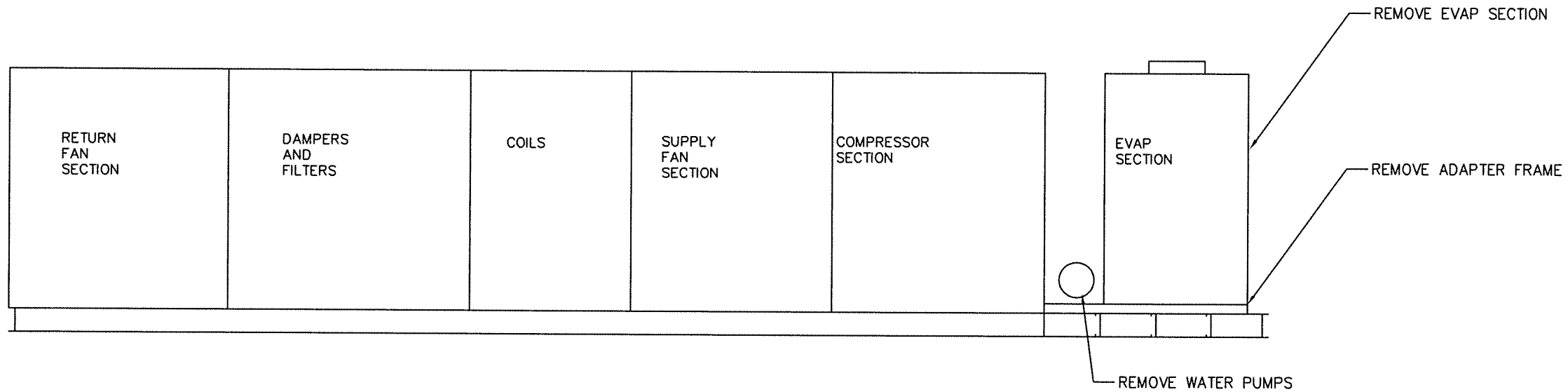

1
M-2
DEMOLITION

DEMOLITION HVAC SHEET NOTES

- ① PROVIDE REFRIGERATION RECLAIM.
- ② DISCONNECT THE EXISTING EVAP SECTION INCLUDING PIPING AND ELECTRICAL CONNECTIONS AS REQUIRED
- ③ REMOVE AND DISPOSE OF ADAPTER FRAME.
- ④ DISASSEMBLE THE EXISTING EVAP SECTION IN ORDER TO REPLACE THE FAN AND COIL ASSEMBLIES.
- ⑤ AIR HANDLING SECTION SHALL REMAIN IN OPERATION DURING REPAIR.

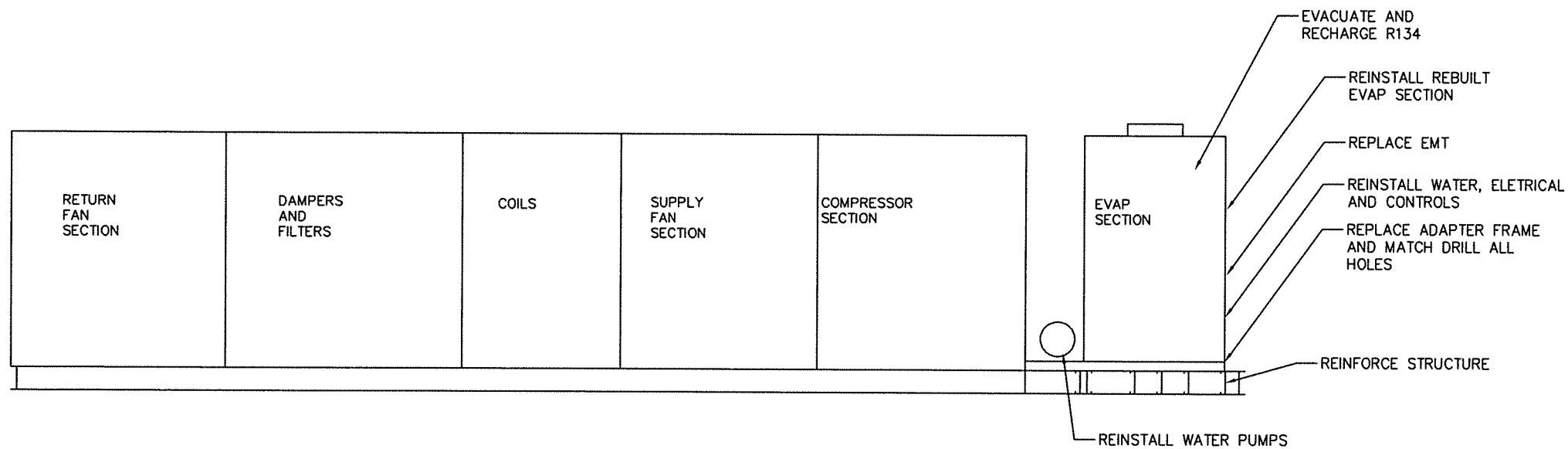

2
M-2
NEW WORK

NEW WORK SHEET NOTES

- ① WELD QTY. 3 NEW C10 MEMBERS INTO EXISTING STRUCTURE.
- ② USE WIRE WHEEL OR EQUAL TO REMOVE RUST AND PAINT BETWEEN C10 MEMBERS.
- ③ INSTALL NEW ADAPTER FRAME.
- ④ CONNECT WATER, ELECTRICAL, CONTROLS, ETC...AFTER REINSTALLING REPAIRED CONDENSING SECTION.
- ⑤ REPLACE LIQUID LINE CORES, EVACUATE SYSTEM AND RECHARGE.
- ⑥ THESE UNITS WERE CUSTOM BUILT BY ENERGY LABS JOB 0308-2473, AND MANY OF THE COMPONENTS ARE AVAILABLE FROM DMG NORTH WHO IS THE AUTHORIZED DEALER. THE PARTS DEPARTMENT CONTACT INFORMATION IS...

EVAN FAIN
DMG NORTH
916-368-7476
- ⑦ ENERGY LAB UNIT MODEL NUMBER IS C104102-FCH-L
JOB NUMBER 0308-2473
- ⑧ SEE 01 15 00 FOR ADDITIONAL INFORMATION ON COMPONENTS

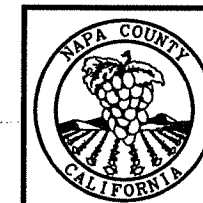

| | | | |
|---|--|-------------------------|--|
| DATE: 5/09/22 | | DESIGN: FL | |
| SCALE: NTS | | DRAWN: FL | |
| FILE NAME: M-3 e-Mechanical.dwg | | CADD: | |
| SURVEY NOTE: | | | |
| DRAWING M-2 | | TITLE DEMO AND NEW WORK | |
| PROJECT TITLE NAPA COUNTY SHERIFF OFFICE HVAC REPAIRS | | | |
| PW 22-08 | | SHEET 2 of 3 | |